

FROMM

OPERATION MANUAL / SPARE PARTS LIST

PNEUMATIC COMBINATION PUSHER TYPE TOOL

MODEL A480

13.4112.01

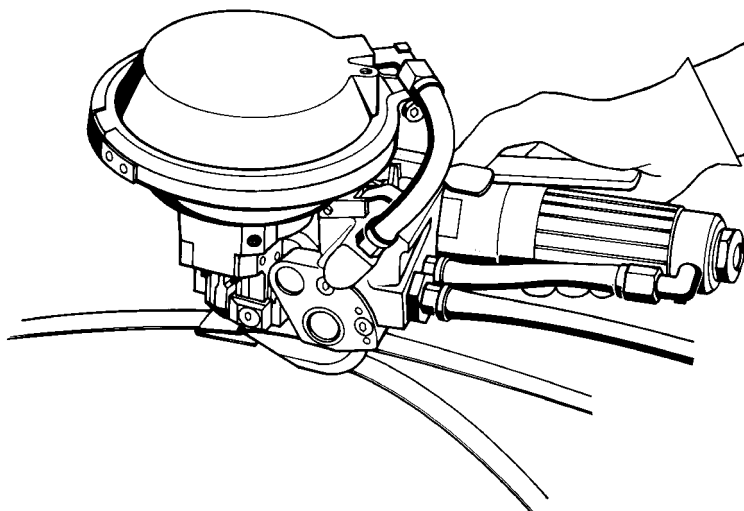

CE Declaration of conformity

We declare that the machine A480
is in conformity with the following standard or
standardised documents:

98/37/EEC

FROMM Holding AG
Hinterbergstrasse 26
CH - 6330 Cham
08.12 2003

A handwritten signature in black ink, appearing to read 'R. Fromm', positioned above the printed name and title.

R.Fromm
Director



	INDEX	PAGE
1	SAFETY INSTRUCTIONS	3
2	WARRANTY CONDITIONS AND LIABILITY	4
3	APPROPRIATE USE	4
4	CHART OF TYPES	4
5	TECHNICAL DATA	5
5.1	Dimensions without suspension bracket	5
5.2	Steel strap	5
5.3	Seals	5
5.4	Joint	5
5.5	Compressed air	5
5.6	Sound information	6
5.7	Vibration information	6
6	INSTALLATION	6
6.1	Compressed air connection	6
6.2	Suspension of tool	6
7	MAINTENANCE	7
7.1	Air - unit	7
7.2	Cleaning	7
7.3	Lubrication	7
8	JOINT CONTROL	7
9	SPARE PARTS LIST 13.4112.01	10
10	OPERATION	13
10.1	Feeding the strap	13
10.2	Introducing the tool	13
10.3	Tensioning the strap	13
10.4	Sealing the strap	14
10.5	Releasing the tool	14
10.6	Tension regulation	14

1 SAFETY INSTRUCTIONS

Read these instructions carefully. Failure to follow these instructions can result in severe personal injury.

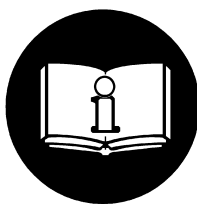

Eye injury hazard

Failure to wear safety glasses with side shields can result in severe eye injury or blindness. Always wear safety glasses with side shields which conform to ANSI Standard Z87.1.



Operation

Tool must not be used by persons not properly trained in their use. Before tensioning strap, read and understand the tool operating instructions. Failure to follow the operating instructions or improper load positioning could result in strap breakage.

Become familiar with your tool and keep fingers away from areas that can pinch or cut.

Joints

You are fully responsible to review the joints made by your tool. Become familiar with the seal control and seal adjustment described in this operation manual. Misformed joints may not secure the load and could cause serious injury. Never handle or ship any load with improperly formed joints.

Dispensing strap

Only dispense strap from a dispenser specifically designed for strap.

Tuck strap end back into dispenser when not in use.

Protective gloves

When handling strap, always wear protective gloves.



Strap warnings

Never use strap as a means of pulling or lifting loads. Failure to follow these warnings can result in severe personal injury.

Strap breakage hazard

Improper operation of the tool, excessive tensioning, using strap not recommended for this tool or sharp corners on the load can result in a sudden loss of strap tension or in strap breakage during tensioning, which could result in the following:

- A sudden loss of balance causing you to fall.
- Both tool and strap flying violently towards your face.

Note as follows:

- If the load corners are sharp, use edge protectors.
- Place the strap correctly around a properly positioned load.
- Positioning yourself in-line with the strap, during tensioning and sealing, can result in severe personal injury from flying strap or tool. When tensioning or sealing, position yourself to one side of the strap and keep all bystanders away.
- Use the correct strap quality, strap width, strap gauge and strap tensile strength recommended in this manual for your tool. Using strap not recommended for this tool can result in strap breakage during tensioning.

Cutting tensioned strap

When cutting strapping, use the proper strapping cutter and keep other personnel and yourself at a safe distance from the strap. Always stand to side of the strap, away from the direction the loosened strap end will fly. Use only cutters designed for strap and never hammers, pliers, hacksaws, axes, etc.

Fall hazard

Keep your working area tidy. Untidiness of your working area may cause a risk of injury. Maintaining improper footing and/or balance when operating the tool can cause you to fall. Before tensioning and especially in elevated areas, always establish good balance. Both feet should be securely placed on a flat, solid surface, especially when working in elevated areas. Do not use the tool when you are in an awkward position.

Pay attention to the rules and regulations for preventions of accident which are valid for the work place.

Tool hazards

A well maintained tool is a safe tool!

Check tool regularly for broken or worn parts. Do not operate a tool with broken or worn parts.

Never modify any tool. Modification can result in severe bodily injury.

2 WARRANTY CONDITIONS AND LIABILITY

FROMM Holding AG warrants all its strapping tools and machine heads during a period of 24 months from the date of installation at the end-user's sight by the distributor, however, not later than 30 months from the date of shipment to the distributor of FROMM Holding AG.

The warranty includes all deficiencies clearly resulting from poor manufacturing or faulty materials. Damage claims as a result of production shutdowns and claims for damage to persons and to property resulting from warranty deficiencies cannot be asserted by the customer.

The warranty excludes:

- wearing parts
- deficiencies resulting from improper installing, incorrect handling and maintaining the tool
- deficiencies resulting from using the tool without or with defective security- and safety devices
- disregard of directions in the operation manual
- arbitrary modifications of the tool
- deficient control of wearing parts
- deficient repair works of the tool
- Use of consumable products not recommended by FROMM Holding AG

We reserve the right to modify the product at any time in order to improve its quality.

3 APPROPRIATE USE

The tool model A480 has been designed to strap packages with steel strapping exclusively.

The warranty / liability excludes:

- non appropriate use of the tool,
- disregard of directions in the operation manual,
- disregard of control- and maintenance instructions.

4 CHART OF TYPES

Item no.	Model	Strap quality: Uniflex and Ultraflex		Max. tensioning force		Max. tensioning speed	
		Strap width	Strap thickness	N	lbs	mm/s	inch/s
13.4050	A480/10/0.38-0.63/4.5	10 mm / 3/8"	0.38-0.63 mm / .015-.025"	4500	1000	100	4.0
13.4052	A480/10/0.38-0.63/2.5	10 mm / 3/8"	0.38-0.63 mm / .015-.025"	2500	560	180	7.1
13.4070	A480/13/0.38-0.63/4.5	13 mm / 1/2"	0.38-0.63 mm / .015-.025"	4500	1000	100	4.0
13.4072	A480/13/0.38-0.63/2.5	13 mm / 1/2"	0.38-0.63 mm / .015-.025"	2500	560	180	7.1
13.4090	A480/16/0.38-0.63/4.5	16 mm / 5/8"	0.38-0.63 mm / .015-.025"	4500	1000	100	4.0
13.4092	A480/16/0.38-0.63/2.5	16 mm / 5/8"	0.38-0.63 mm / .015-.025"	2500	560	180	7.1
13.4110	A480/19/0.38-0.63/4.5	19 mm / 3/4"	0.38-0.63 mm / .015-.025"	4500	1000	100	4.0
13.4112	A480/19/0.38-0.63/2.5	19 mm / 3/4"	0.38-0.63 mm / .015-.025"	2500	560	180	7.1

Uniflex = Strap with max. tensile strength of 850 N/mm² (123 000 psi)

Ultraflex = Strap with max. tensile strength of 1100 N/mm² (160 000 psi)

5 TECHNICAL DATA

5.1 Dimensions without suspension bracket

	Tool	Package
Length:	304 mm / 11.86"	440 mm / 17.16"
Width:	145 mm / 5.66"	253 mm / 9.87"
Height:	155 mm / 6.05"	170 mm / 6.63"
Weight:	Net	Gross
	4.5 kg / 9.9 lbs	5 kg / 11 lbs

5.2 Steel strap

Width:	10 - 19 mm / 3/8" - 3/4" (see chart of types)
Thickness:	0.3 - 0.63 mm / .015 - .025" .
Quality:	The A480 model allows the use of all current steel straps with tensile strengths ranging from 87 000 to 160 000 psi (600 - 1100 N/mm ²). Straps with a low breaking elongation are not suitable for the A480 tool.

5.3 Seals

Strap width:	Seal dimensions:
10 mm / 3/8"	10x22x0.6 / 3/8"x7/8"x0.024", with overlapping flanges
13 mm / 1/2 "	13x22x0.6 / 1/2"x7/8"x0.024", with overlapping flanges
16 mm / 5/8"	16x22x0.6 / 5/8"x7/8"x0.024", with overlapping flanges
19 mm / 3/4"	19x22x0.6 / 3/4"x7/8"x0.024", with overlapping flanges

5.4 Joint

Joint strength: approx. 55% of the strap's tensile strength.
A single-notch (one pair of cut notches) is made per cycle.

5.5 Compressed air

Joining thread:	G 1/4"	
Air tube:	Min. inside diameter = 8 mm / 3/8"	
Working pressure:	4.2 - 6 bar / 60 - 87 psi	
Max. air pressure:	6 bar / 87 psi	
Air consumption:	Tensioning	Sealing
	450 NI / 15.8 cu.ft. per minute	2.5 NI / 0.09 cu.ft. per cycle

5.6 Sound information

The A-weighted equivalent continuous sound level at the work place of the machine operator is typical 83 dB (A).

This value was determined according to DIN 45 635 T3 (11.85).

5.7 Vibration information

The weighted effective value of the acceleration typically amounts to less than 2,5m/s².

This value was determined according to DIN EN 28 662 T1 (01.93).

6 INSTALLATION

6.1 Compressed air connection

The compressed air is preferably connected to the tube connection A48.1306 using a coupling. An air-unit consisting of a separator for water and dirt, a pressure regulator with a manometer and a lubricator should be installed within a range of 15 ft / 5 meters. The compressed air must be free from dirt, rust and moisture.

6.2 Suspension of tool

It is possible to suspend the tool in its three main working positions on a spring loaded balancer by providing the tool with the necessary suspension bracket. The standard suspension bracket A48.1301 is always automatically supplied with the tool.

Standard position

Standard suspension bracket A48.1301.
2 screws N1.1125

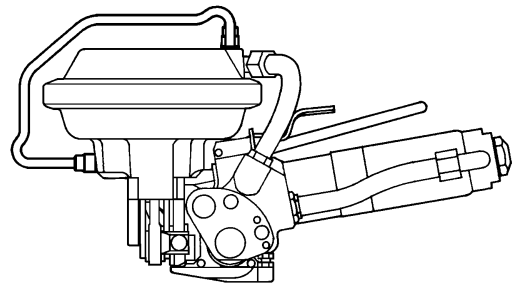

Vertical position

Standard suspension bracket A48.1301
2 screws N1.1125

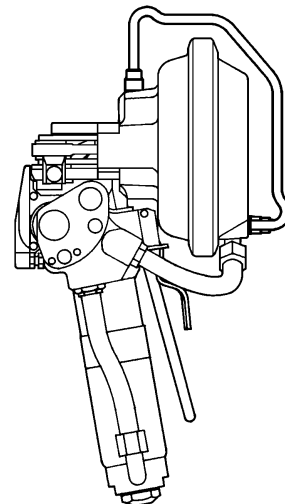

Horizontal position

Side suspension bracket A48.1304.
2 screws N1.1125
Ordering separately

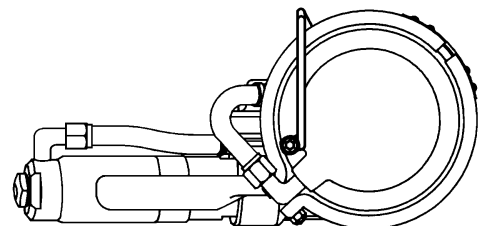

7 MAINTENANCE

Depending on the working conditions and the use of the tool the following maintenance has to be made periodically:

7.1 Air - unit

- Checking the air-pressure daily.
- Checking oil-level daily.
- The water separator must be emptied before it is full (unless automatic).
- The filter has to be cleaned following the instructions of the manufacturer of the air- unit.

Oil for the air-unit

HL or CL ISO-VG 10

7.2 Cleaning

If impact of dirt and dust is considerable and if painted straps are used the feed wheel must be cleaned regularly. Normally it is sufficient to blow out this part by using an air gun.

7.3 Lubrication

The worm gear is filled with MOLYKOTE BR 2 PLUS. Use the same type of grease after repairs. When being exchanged, all valve parts and other movable parts have to be greased with grease of type ESSO BEACON 2 or with any equivalent product.

The diaphragm must always be rubbed with TALCUM before being installed.

8 JOINT CONTROL

A regular control of the joint is necessary. The joint can be checked visually and the person controlling can easily judge the quality of the joint. Following illustration shows a proper joint:

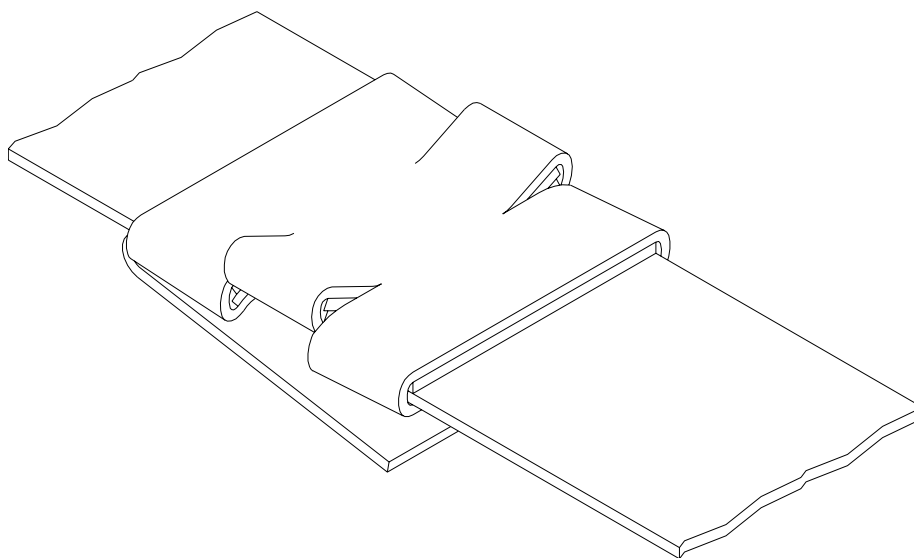

Sharp edged or misformed joints which do not appear as shown have to be taken away from the load immediately. The tensile strength of these joints is insufficient and they could cause serious injury. Having faulty joints proceed as follows:

- Checking the sealing cycle for improper use.(see OPERATION)
- Having faulty joints in spite of proper use, inspect the tool for worn or damaged parts. In case of wearing out or damaging replace tool parts as needed.

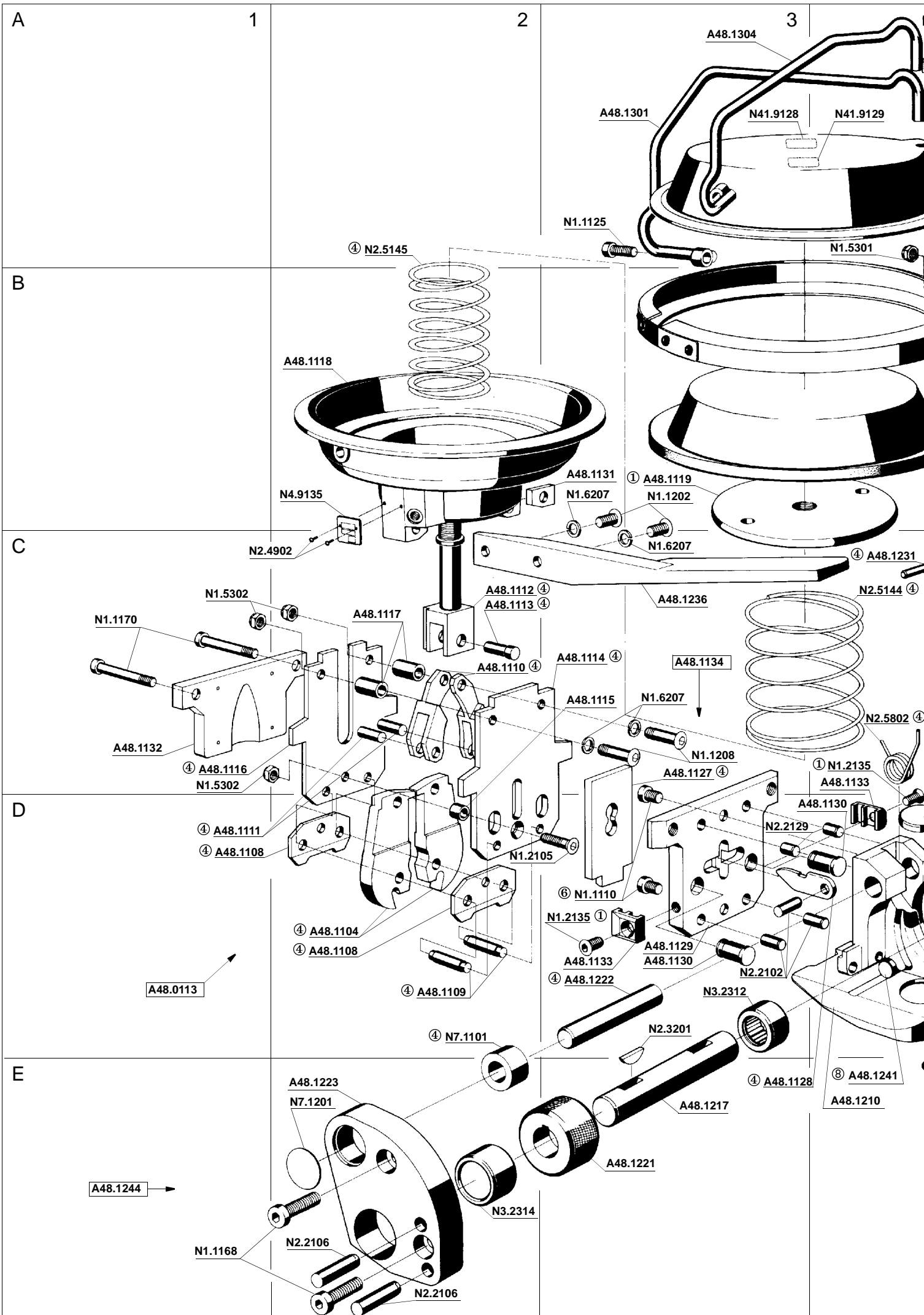

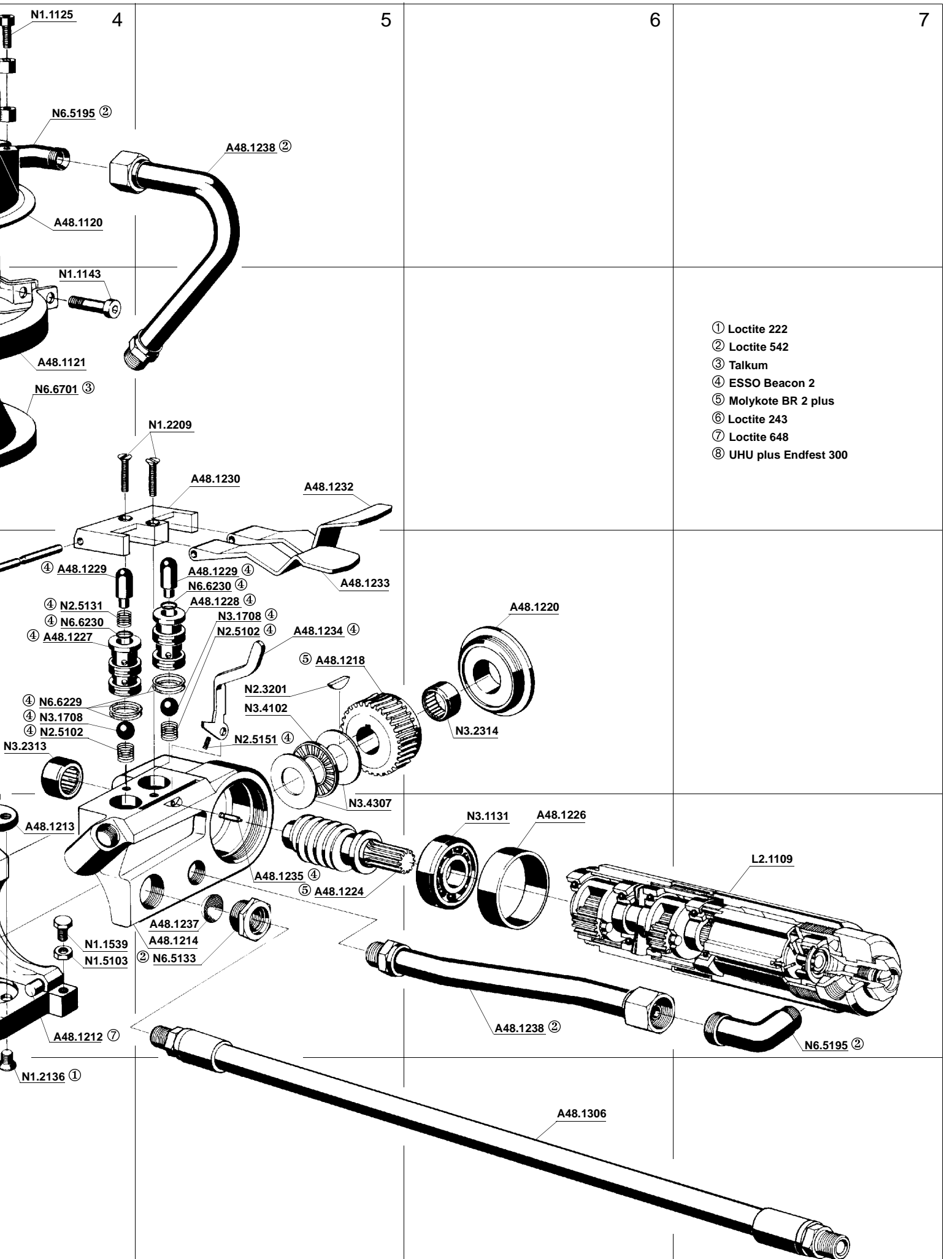

- ① Loctite 222
- ② Loctite 542
- ③ Talkum
- ④ ESSO Beacon 2
- ⑤ Molykote BR 2 plus
- ⑥ Loctite 243
- ⑦ Loctite 648
- ⑧ UHU plus Endfest 300

9 SPARE PARTS LIST 13.4112.01

13.4112.01	A480/19/0.38-0.63/2.5		A480.0001.01		11.06.02	
Item-No.		in group	Pcs.	Description	Dimension	Field
[A48.0113]			1	JAW ASSEMBLY	19 MM	D1
A48.1104	*	A48.0113	2	CUTTING JAW		D2
A48.1108	*	A48.0113	2	NOTCHING KNIFE		D1+
A48.1109		A48.0113	2	JAW PIN		D2
A48.1110		A48.0113	2	FRONT TOGGLE LINK		C2
A48.1111		A48.0113	2	LEVER BOLT		D1
A48.1112		A48.0113	1	PISTON ROD		C2
A48.1113		A48.0113	1	ROD BAR BOLT		C2
A48.1114		A48.0113	1	SIDE PLATE		C3
A48.1115		A48.0113	1	SPACER BUSH		C3
A48.1116		A48.0113	1	SIDE PLATE		C1
A48.1117		A48.0113	2	SPACER BUSH		C2
[A48.1118]			1	CYLINDER BOTTOM		B2
A48.1119			1	PISTON PLATE		B3
[A48.1120]			1	CYLINDER COVER		A4
[A48.1121]			1	TENSIONING RING		B4
A48.1127	*		1	CUTTER	19 MM	C3
A48.1128	*		1	CUTTER JACK		E3
[A48.1129]		A48.1134	1	CONNECTION PLATE		D3
A48.1130		A48.1134	2	STOP BOLT		D3+
A48.1131			1	JAW GUIDE		B3
A48.1132			1	COVER PLATE		C1
A48.1133			2	TONG GUIDE		D3+
[A48.1134]			1	CONNECTION PLATE		C3
[A48.1210]	*		1	TENSIONING BODY		D4
A48.1212		A48.1210	1	DISTANCE BOLT		D4
A48.1213	*		1	SLIDE PLATE		D4
[A48.1214]			1	GEAR BODY		D5
A48.1217			1	TENSION SHAFT		E3
A48.1218			1	WORM WHEEL		C5
A48.1220			1	END COVER		C6
A48.1221	*		1	TENSIONING WHEEL		E3
A48.1222			1	PIVOT PIN		D3
A48.1223		A48.1244	1	END COVER		E2
A48.1224			1	WORM		D5
A48.1226			1	BEARING JACKET		D6
A48.1227			1	VALVE SHELL		C4
A48.1228			1	VALVE SHELL		C5
A48.1229			2	VALVE BOLT		C4+
A48.1230			1	LEVER BODY		B5
A48.1231			1	SHAFT		C4
A48.1232			1	TENSIONER VALVE LEVER		B5
A48.1233			1	SEALING VALVE LEVER		C5
A48.1234			1	CATCH		C5
A48.1235			1	CATCH PIN		D5
A48.1236			1	HANDLE		C3
A48.1237			1	SIEVE		D5
[A48.1238]			2	HOSE		A5+
A48.1241		A48.1210	1	DISTANCE DISK		E4
[A48.1244]			1	END COVER		E1
[A48.1301]			1	SUSPENSION		A3

[] = Group

* = Wearing parts

13.4112.01	A480/19/0.38-0.63/2.5		A480.0001.01			11.06.02
Item-No.		in group	Pcs.	Description	Dimension	Field
[A48.1306]			1	HOSE CONNECTION		E6
[L2.1109]			1	AIR MOTOR		--
L2.1201		L2.1109	1	EXHAUST RING		--
L2.1203		L2.1212	1	PLASTIC JACKET		--
[L2.1212]		L2.1109	1	HOUSING		--
L2.1301		L2.1109	1	END PLATE		--
L2.1302		L2.1109	1	PARALLEL PIN		--
L2.1303		L2.1109	1	CYLINDER		--
L2.1304	*	L2.1109	5	VANE		--
L2.1305		L2.1109	1	ROTOR		--
L2.1306		L2.1314	1	KEY		--
L2.1308		L2.1109	1	SILENCER		--
L2.1313		L2.1109	1	BEARING RING		--
[L2.1314]		L2.1109	1	END PLATE		--
L2.1315		L2.1109	1	PLANET SHAFT		--
L2.1316		L2.1109	2	GEAR WHEEL		--
L2.1317		L2.1109	2	NEEDLE CAGE		--
L2.1318		L2.1109	2	SHAFT		--
L2.1319		L2.1109	1	INTERMEDIATE WHEEL		--
L2.1402		L2.1109	32	BEARING NEEDLE		--
L2.1403		L2.1109	2	GEAR WHEEL		--
L2.1404		L2.1109	2	SHAFT		--
L2.1405		L2.1109	1	BEARING RING		--
L2.1408		L2.1109	1	PLANETARY CAGE		--
L2.1409		L2.1413	1	AIR INLET RING		--
L2.1410		L2.1413	1	TENSION SCREW		--
L2.1411		L2.1413	1	THROTTLE HEAD		--
L2.1412		L2.1413	1	THROTTLE SCREW		--
[L2.1413]		L2.1109	1	AIR INLET HEAD		--
L2.1505		L2.1109	1	KEY		--
N1.1110			2	SCREW	M5 X 8	D3
N1.1125			2	SCREW	M6 X 16	A3+
N1.1125		A48.1301	2	SCREW	M6 X 16	A3
N1.1143			1	SCREW	M6 X 35	B4
N1.1168			2	SCREW	M5 X 16	E1
N1.1170			2	SCREW	M6 X 35	C1
N1.1202			2	SCREW	M5 X 10	B3
N1.1208		A48.0113	2	SCREW	M5 X 25	C3
N1.1539			1	HEXAGON SCREW	M5 X 14	D4
N1.2105		A48.0113	1	COUNTERSUNK SCREW	M5 X 25	D2
N1.2135			2	COUNTERSUNK SCREW	M5 X 12	D3+
N1.2136			1	COUNTERSUNK SCREW	M5 X 8	E4
N1.2209			2	COUNTERSUNK SCREW	M4 X 18	B5
N1.5103			1	HEXAGON NUT	M5	D4
N1.5301			1	RETAINING NUT	M6	A4
N1.5302		A48.0113	3	RETAINING NUT	M5	C1
N1.6207			2	SPRING LOCK WASHER	M5	B3+
N1.6207		A48.0113	2	SPRING LOCK WASHER	M5	C3
N1.6701		L2.1109	2	TOOTH LOCK WASHER		--
N2.2102			1	PARALLEL PIN	5 m6 X 16	D3
N2.2102		A48.1134	2	PARALLEL PIN	5 m6 X 16	D3
N2.2106			2	PARALLEL PIN	5 m6 X 20	E2
N2.2129		A48.1134	2	PARALLEL PIN	5 m6 X 10	D3

[] = Group

* = Wearing parts

13.4112.01	A480/19/0.38-0.63/2.5		A480.0001.01			11.06.02
Item-No.		in group	Pcs.	Description	Dimension	Field
N2.3201			2	WOODRUFF KEY	4 X 6.5 X 15.72	D3+
N2.4902			2	HAMMER HEAD BOLT	1.85 X 4.76	C2
N2.5102			2	PRESSURE SPRING	0.6 X 8 X 14/6	C4+
N2.5131			1	PRESSURE SPRING	0.5 X 6 X 15/7.5	C4
N2.5144			1	PRESSURE SPRING	3 X 54 X 125/6.5	C4
N2.5145			1	PRESSURE SPRING	2.8 X 36 X 55/5	A2
N2.5151			1	PRESSURE SPRING	0.3 X 2.8 X 11/11.5	C5
N2.5802			1	BENDING SPRING	2.5 X 11.5/3.25	C4
N3.1102		L2.1109	4	BALL BEARING	15 X 32 X 9	--
N3.1108		L2.1109	1	BALL BEARING	6 X 19 X 6	--
N3.1109		L2.1109	1	BALL BEARING	8 X 22 X 7	--
N3.1131			1	BALL BEARING	12 X 32 X 10	D6
N3.1708			2	BALL	10 MM	C4+
N3.2312			1	NEEDLE BUSH	15 X 21 X 14	D3
N3.2313			1	NEEDLE CASE	12 X 18 X 12	C4
N3.2314			1	NEEDLE CASE	15 X 21 X 12	C6
N3.2314		A48.1244	1	NEEDLE CASE	15 X 21 X 12	E2
N3.4102			1	THRUST BEARING CAGE	15 X 28 X 2	C5
N3.4307			2	THRUST RACE	15 X 28 X 1	D5
N41.9128			1	ADHESIVE LABEL	30 X 10 X 0.1	A4
N41.9129			1	ADHESIVE LABEL	p max. 6 bar/87 psi	A4
N4.9135			1	NUMBER PLATE	<<A480>>	B2
N6.5133			1	REDUCING COUPLING		D5
N6.5195			2	FITTING		A4+
N6.6229			4	O-RING	14 X 1	C4
N6.6230			2	O-RING	8 X 1.5	C4+
N6.6234		L2.1413	1	O-RING	7.1 X 1.6	--
N6.6505		L2.1413	1	FLAT SEAL	21 X 17 X 1,5	--
N6.6701			1	DIAPHRAGM		B4
N7.1101		A48.1244	1	BUSH	10 X 15 X 10	D2
N7.1201		A48.1244	1	SEALING DISK	16	E2

[] = Group

* = Wearing parts

10 OPERATION

10.1 Feeding the strap

The strap is fed through the seal, around the package to be strapped and again through the seal. The strap end is then bent. The operator then tensions the loose loop manually making sure that the bent strap end is adjacent to the object to be strapped.



Always wear safety glasses with side shields which conform to ANSI Standard Z87.1.



When handling strap, always wear protective gloves.

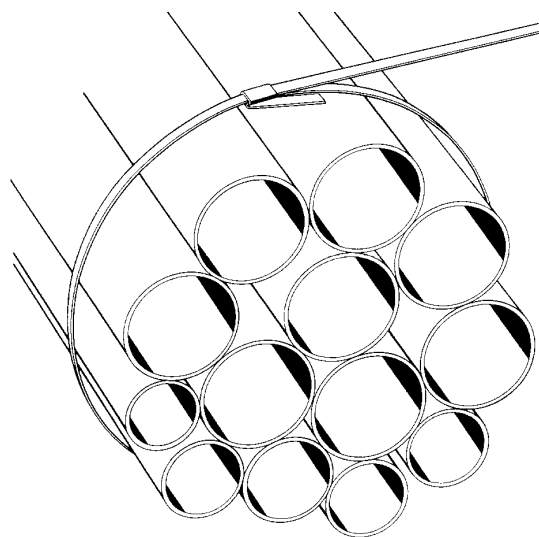

10.2 Introducing the tool

The upper strap is held with the left hand; the right hand lifts the air motor and introduces the tool from the right to the left and from the rear to the front. The air motor is then released.

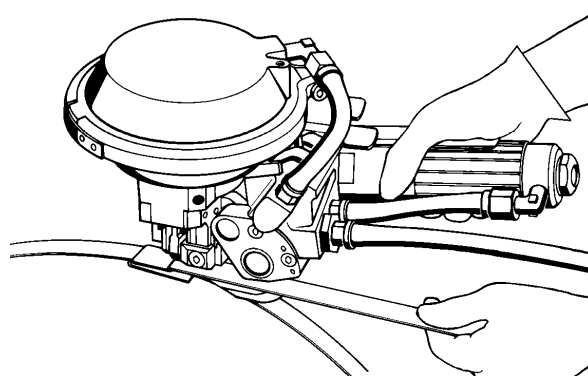

10.3 Tensioning the strap

The tension valve lever A48.1232 is pressed down. The lever is caught completely and the strap is tensioned until the air motor stalls. If the cycle has to be interrupted the catch A48.1234 has to be pressed to the left.

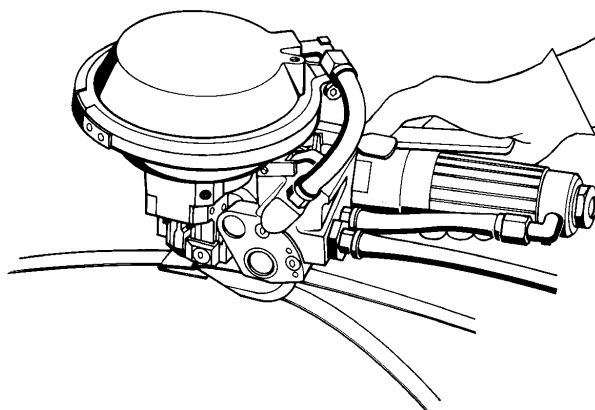

10.4 Sealing the strap

The sealing valve lever A48.1233 is pressed down until the seal is notched and the upper strap sheared; the tensioning process is interrupted automatically.

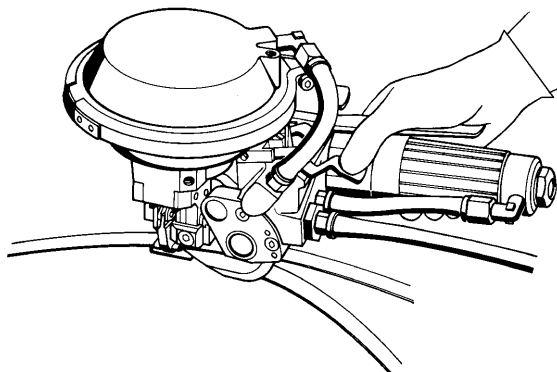

10.5 Releasing the tool

The tool can be released from the strapping without any further action after completing the strapping cycle. By lifting the air motor the strap end is removed from the tool.

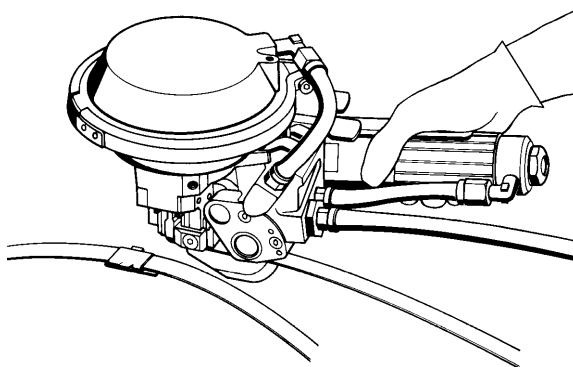

10.6 Tension regulation

The tension is regulated by the continuous adjustment of the throttle screw L2.1412. The air supply is reduced by turning the screw clockwise. The throttle screw is located at the rear end of the air motor.

